

Vista in pianta  
plan view

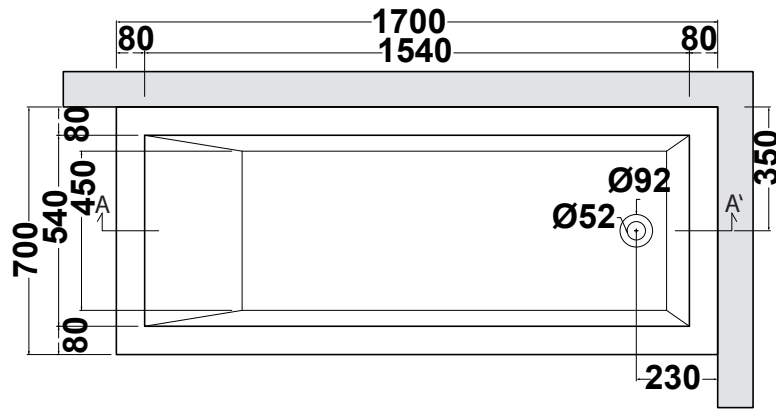

Sezione A/A'  
Section A/A'

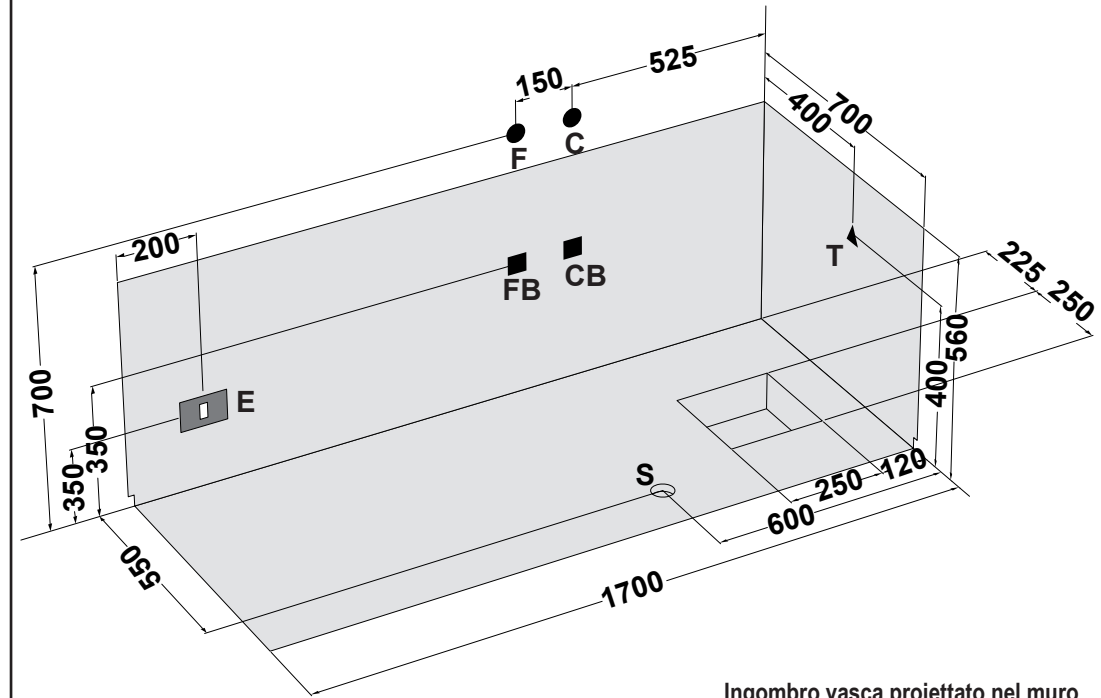
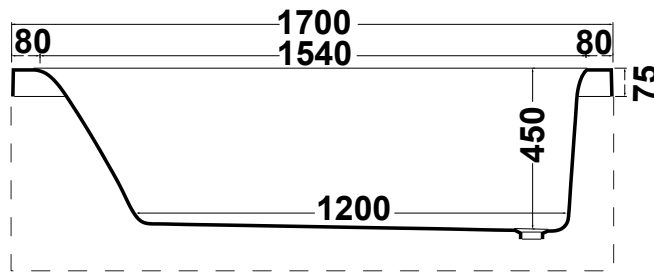

Ingombro vasca proiettato nel muro  
Bath overall dimensions as projected on the wall

①	CARATTERISTICHE IDRAULICHE	CARATTERISTICHE ELETTRICHE IDROMASSAGGIO	REQUISITI DI PREINSTALLAZIONE	COMBINAZIONI RUBINETTERIA																				
<p><b>N.B. L'INSTALLAZIONE DEVE AVVENIRE A PAVIMENTO E PARETI FINITE</b></p> <p>Peso netto: <b>Kg 58</b>                      Peso spedizione: <b>Kg 63</b>                      Volume spedizione: <b>m<sup>3</sup> = 0,777</b>                      Contenuto acqua: <b>Lt 220</b></p>	<p>Numero jets: 6</p> <p>jets airpool : 12</p>	<table border="1"> <tr> <td>V</td> <td>HZ</td> <td>KW</td> <td>A</td> </tr> <tr> <td>220/240</td> <td>50/60</td> <td>0,78</td> <td>4,5</td> </tr> <tr> <td colspan="4"><b>ELETTRO POMPA AIRPOOL</b></td> </tr> <tr> <td>V</td> <td>HZ</td> <td>KW</td> <td>A</td> </tr> <tr> <td>220/230</td> <td>50/60</td> <td>0,65</td> <td>3</td> </tr> </table>	V	HZ	KW	A	220/240	50/60	0,78	4,5	<b>ELETTRO POMPA AIRPOOL</b>				V	HZ	KW	A	220/230	50/60	0,65	3	<p>C : Allaccio acqua calda rubinetteria parete: 1/2"</p> <p>F : Allaccio acqua fredda rubinetteria parete: 1/2"</p> <p>CB : Allaccio acqua calda bordo vasca: 1/2"</p> <p>FB : Allaccio acqua fredda bordo vasca: 1/2"</p> <p>T : Allaccio miscelatore per erogazione da troppopieno: 1/2"</p> <p>S : Allaccio scarico incassato a pavimento: 1-1/2"</p> <p>E : Allaccio elettrico idromassaggio (pressacavo PG 11): IPX5</p>	<p>C F : Rubinetteria parete</p> <p>CFT: Rubinetteria parete con erogazione troppopieno</p> <p>CB BF: Rubinetteria bordo vasca</p>
V	HZ	KW	A																					
220/240	50/60	0,78	4,5																					
<b>ELETTRO POMPA AIRPOOL</b>																								
V	HZ	KW	A																					
220/230	50/60	0,65	3																					
GB	WATER SYSTEM SPECIFICATION	POWER SYSTEM SPECIFICATION	CONDITION REQUIRED BEFORE THE INSTALLATION	TAPS COMBINATION																				
<p><b>N.B. THE INSTALLATION MUST BE CARRIED OUT WITH FLOOR AND WALLS ALRESDY TILED</b></p> <p>Net weight: <b>Kg 58</b>                      total weight with package: <b>Kg 63</b>                      Volume with package: <b>m<sup>3</sup> = 0,777</b>                      Water capacity: <b>Lt 220</b></p>	<p>Numero jets: 6</p> <p>jets airpool : 12</p>	<table border="1"> <tr> <td>V</td> <td>HZ</td> <td>KW</td> <td>A</td> </tr> <tr> <td>220/240</td> <td>50/60</td> <td>0,78</td> <td>4,5</td> </tr> <tr> <td colspan="4"><b>ELECTRO PUMP AIRPOOL</b></td> </tr> <tr> <td>V</td> <td>HZ</td> <td>KW</td> <td>A</td> </tr> <tr> <td>220/230</td> <td>50/60</td> <td>0,65</td> <td>3</td> </tr> </table>	V	HZ	KW	A	220/240	50/60	0,78	4,5	<b>ELECTRO PUMP AIRPOOL</b>				V	HZ	KW	A	220/230	50/60	0,65	3	<p>C : Wall taps outlet for hot water: 1/2"</p> <p>F : Wall taps outlet for cold water: 1/2"</p> <p>CB : Bath edge taps outlet for hot water: 1/2"</p> <p>FB : Bath edge taps outlet for cold water: 1/2"</p> <p>T : Single outlet for mixed water to supply by overflowing: 1/2"</p> <p>S : Drainage outlet installed in the floor: 1-1/2"</p> <p>E : Power outlet for the wirpool (cabling press box PG 11): IPX5</p>	<p>C F : Wall taps</p> <p>CFT: Wall taps with water supply by overflowing</p> <p>CB BF: Bath edge taps</p>
V	HZ	KW	A																					
220/240	50/60	0,78	4,5																					
<b>ELECTRO PUMP AIRPOOL</b>																								
V	HZ	KW	A																					
220/230	50/60	0,65	3																					

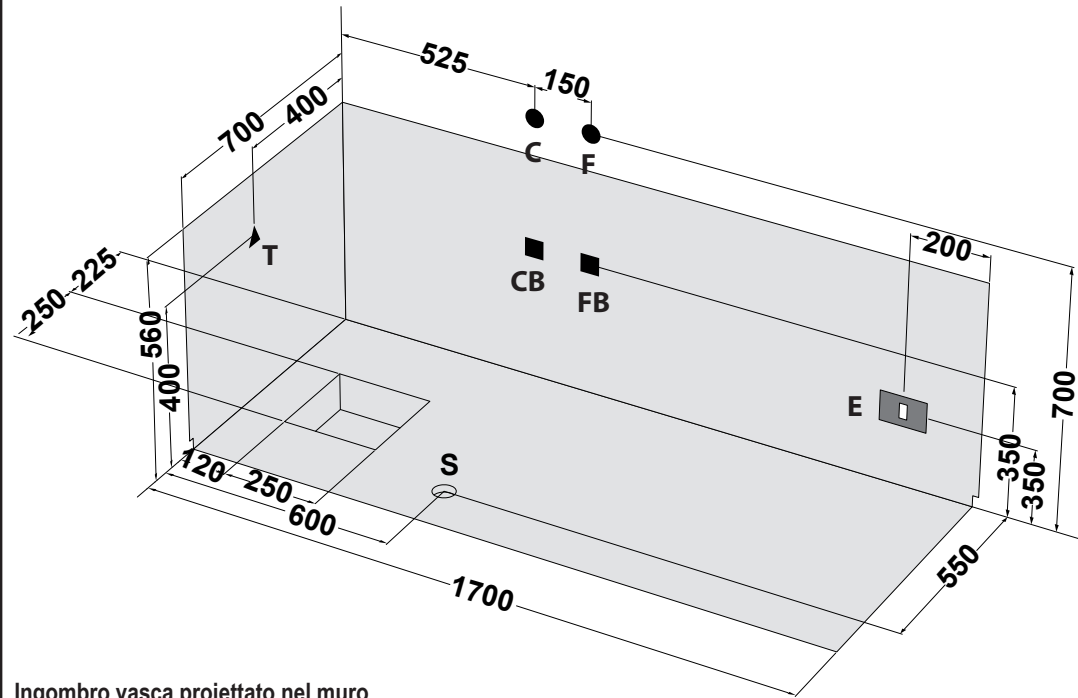
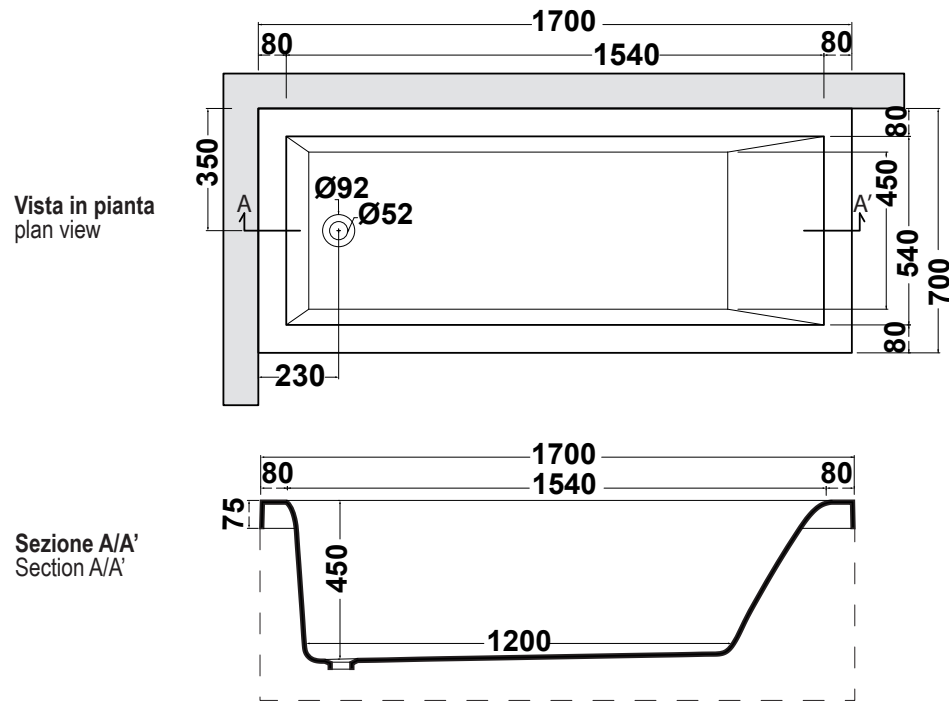

Ingombro vasca proiettato nel muro  
Bath overall dimensions as projected on the wall

①	CARATTERISTICHE IDRAULICHE	CARATTERISTICHE ELETTRICHE IDROMASSAGGIO	REQUISITI DI PREINSTALLAZIONE	COMBINAZIONI RUBINETTERIA																
<p><b>N.B. L'INSTALLAZIONE DEVE AVVENIRE A PAVIMENTO E PARETI FINITE</b></p> <p>Peso netto: <b>Kg 58</b>                      Peso spedizione: <b>Kg 63</b>                      Volume spedizione: <b>m<sup>3</sup> = 0,777</b>                      Contenuto acqua: <b>Lt 220</b></p>	<p>Numero jets: 6</p> <hr/> <p>jets airpool : 12</p>	<table border="1"> <tr> <td>V</td> <td>HZ</td> <td>KW</td> <td>A</td> </tr> <tr> <td>220/240</td> <td>50/60</td> <td>0,78</td> <td>4,5</td> </tr> </table> <p><b>ELETTRO POMPA AIRPOOL</b></p> <table border="1"> <tr> <td>V</td> <td>HZ</td> <td>KW</td> <td>A</td> </tr> <tr> <td>220/230</td> <td>50/60</td> <td>0,65</td> <td>3</td> </tr> </table>	V	HZ	KW	A	220/240	50/60	0,78	4,5	V	HZ	KW	A	220/230	50/60	0,65	3	<p>C : Allaccio acqua calda rubinetteria parete: 1/2"                      F : Allaccio acqua fredda rubinetteria parete: 1/2"                      CB : Allaccio acqua calda bordo vasca: 1/2"                      FB : Allaccio acqua fredda bordo vasca: 1/2"                      T : Allaccio miscelatore per erogazione da troppopieno: 1/2"                      S : Allaccio scarico incassato a pavimento: 1-1/2"                      E : Allaccio elettrico idromassaggio (pressacavo PG 11): IPX5</p>	<p>C F : Rubinetteria parete                      ● ●                      CFT: Rubinetteria parete con erogazione troppopieno                      ● ● ▲                      CB FB: Rubinetteria bordo vasca                      ■ ■</p>
V	HZ	KW	A																	
220/240	50/60	0,78	4,5																	
V	HZ	KW	A																	
220/230	50/60	0,65	3																	
GB	WATER SYSTEM SPECIFICATION	POWER SYSTEM SPECIFICATION	CONDITION REQUIRED BEFORE THE INSTALLATION	TAPS COMBINATION																
<p><b>N.B. THE INSTALLATION MUST BE CARRIED OUT WITH FLOOR AND WALLS ALRESDY TILED</b></p> <p>Net weight: <b>Kg 58</b>                      total weight with package: <b>Kg 63</b>                      Volume with package: <b>m<sup>3</sup> = 0,777</b>                      Water capacity: <b>Lt 220</b></p>	<p>Numero jets: 6</p> <hr/> <p>jets airpool : 12</p>	<table border="1"> <tr> <td>V</td> <td>HZ</td> <td>KW</td> <td>A</td> </tr> <tr> <td>220/240</td> <td>50/60</td> <td>0,78</td> <td>4,5</td> </tr> </table> <p><b>ELECTRO PUMP AIRPOOL</b></p> <table border="1"> <tr> <td>V</td> <td>HZ</td> <td>KW</td> <td>A</td> </tr> <tr> <td>220/230</td> <td>50/60</td> <td>0,65</td> <td>3</td> </tr> </table>	V	HZ	KW	A	220/240	50/60	0,78	4,5	V	HZ	KW	A	220/230	50/60	0,65	3	<p>C : Wall taps outlet for hot water: 1/2"                      F : Wall taps outlet for cold water: 1/2"                      CB : Bath edge taps outlet for hot water: 1/2"                      FB : Bath edge taps outlet for cold water: 1/2"                      T : Single outlet for mixed water to supply by overflowing: 1/2"                      S : Drainage outlet installed in the floor: 1-1/2"                      E : Power outlet for the wirpool (cabling press box PG 11): IPX5</p>	<p>C F : Wall taps                      ● ●                      CFT: Wall taps with water supply by overflowing                      ● ● ▲                      CB FB: Bath edge taps                      ■ ■</p>
V	HZ	KW	A																	
220/240	50/60	0,78	4,5																	
V	HZ	KW	A																	
220/230	50/60	0,65	3																	

Vista in pianta  
plan view

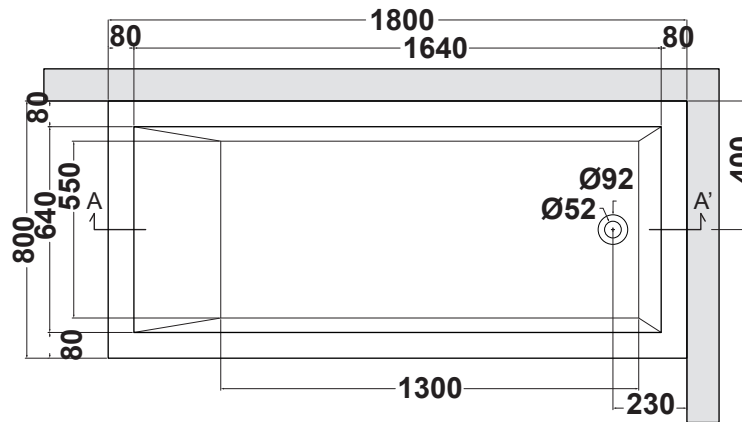

Sezione A/A'  
Section A/A'

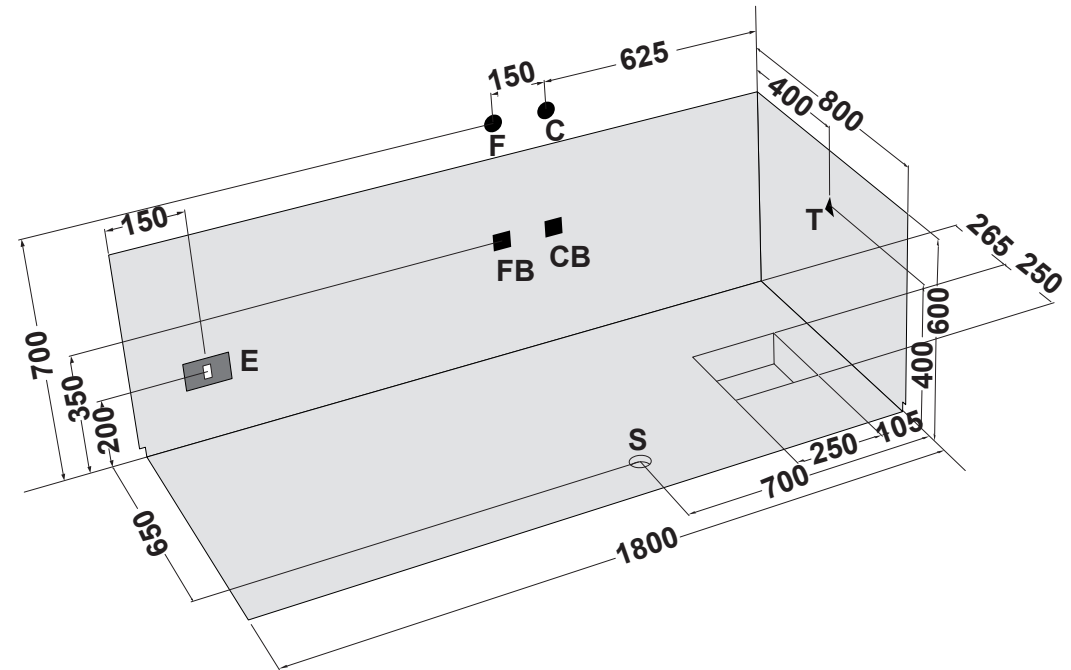
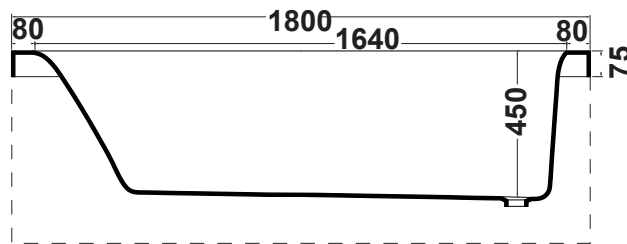

Ingombro vasca proiettato nel muro  
Bath overall dimensions as projected on the wall

①	CARATTERISTICHE IDRAULICHE	CARATTERISTICHE ELETTRICHE IDROMASSAGGIO	REQUISITI DI PREINSTALLAZIONE	COMBINAZIONI RUBINETTERIA
<p><i>N.B. L'INSTALLAZIONE DEVE AVVENIRE A PAVIMENTO E PARETI FINITE</i></p> <p>Peso netto: <b>Kg 60</b>                      Peso spedizione: <b>Kg 65</b>                      Volume spedizione: <b>m<sup>3</sup> = 0,777</b>                      Contenuto acqua: <b>Lt 260</b></p>	<p>Numero jets: 8</p> <hr/> <p>jets airpool : 12</p>	<p>V HZ KW A 220/240 50/60 0,78 4,5</p> <p><b>ELETTRO POMPA AIRPOOL</b></p> <p>V HZ KW A 220/230 50/60 0,65 3</p>	<p>C : Allaccio acqua calda rubinetteria parete: 1/2"                      F : Allaccio acqua fredda rubinetteria parete: 1/2"                      CB : Allaccio acqua calda bordo vasca: 1/2"                      FB : Allaccio acqua fredda bordo vasca: 1/2"                      T : Allaccio miscelatore per erogazione da troppopieno: 1/2"                      S : Allaccio scarico incassato a pavimento: 1-1/2"                      E : Allaccio elettrico idromassaggio (pressacavo PG 11): IPX5</p>	<p>C F : Rubinetteria parete                      ● ●                      CFT: Rubinetteria parete con erogazione troppopieno                      ● ● ▲                      CB FB: Rubinetteria bordo vasca                      ■ ■</p>
GB	WATER SYSTEM SPECIFICATION	POWER SYSTEM SPECIFICATION	CONDITION REQUIRED BEFORE THE INSTALLATION	TAPS COMBINATION
<p><i>N.B. THE INSTALLATION MUST BE CARRIED OUT WITH FLOOR AND WALLS ALRESDY TILED</i></p> <p>Net weight: <b>Kg 60</b>                      total weight with package: <b>Kg 65</b>                      Volume with package: <b>m<sup>3</sup> = 0,777</b>                      Water capacity: <b>Lt 260</b></p>	<p>Numero jets: 8</p> <hr/> <p>jets airpool : 12</p>	<p>V HZ KW A 220/240 50/60 0,78 4,5</p> <p><b>ELECTRO PUMP AIRPOOL</b></p> <p>V HZ KW A 220/230 50/60 0,65 3</p>	<p>C : Wall taps outlet for hot water: 1/2"                      F : Wall taps outlet for cold water: 1/2"                      CB : Bath edge taps outlet for hot water: 1/2"                      FB : Bath edge taps outlet for cold water: 1/2"                      T : Single outlet for mixed water to supply by overflowing: 1/2"                      S : Drainage outlet installed in the floor: 1-1/2"                      E : Power outlet for the wirpool (cabling press box PG 11): IPX5</p>	<p>C F : Wall taps                      ● ●                      CFT: Wall taps with water supply by overflowing                      ● ● ▲                      CB FB: Bath edge taps                      ■ ■</p>

Vista in pianta  
plan view

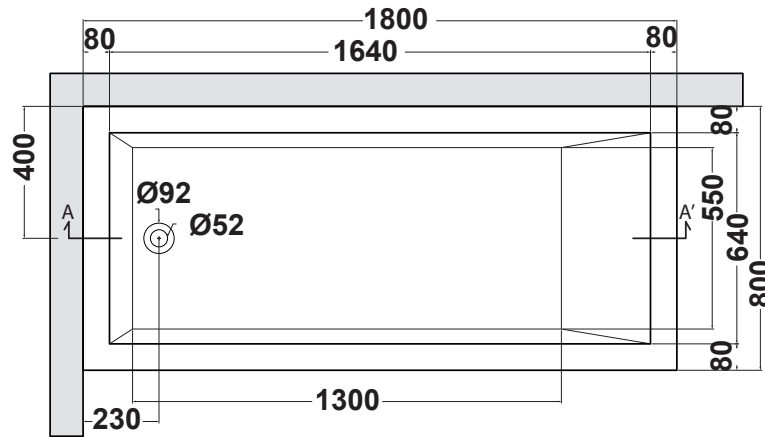

Sezione A/A'  
Section A/A'

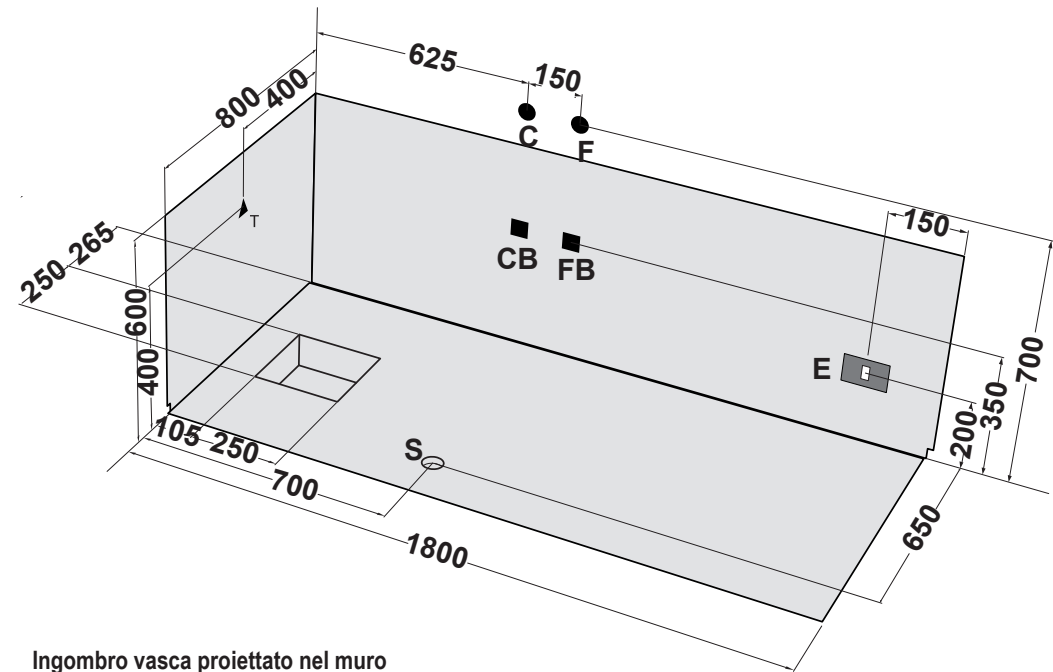
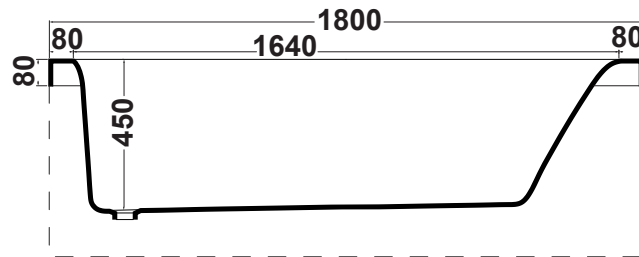

Ingombro vasca proiettato nel muro  
Bath overall dimensions as projected on the wall

①	CARATTERISTICHE IDRAULICHE	CARATTERISTICHE ELETTRICHE IDROMASSAGGIO	REQUISITI DI PREINSTALLAZIONE	COMBINAZIONI RUBINETTERIA
<p><i>N.B. L'INSTALLAZIONE DEVE AVVENIRE A PAVIMENTO E PARETI FINITE</i></p> <p>Peso netto: <b>Kg 60</b> Peso spedizione: <b>Kg 65</b> Volume spedizione: <b>m<sup>3</sup> = 0,777</b> Contenuto acqua: <b>Lt 260</b></p>	<p>Numero jets: 8</p> <hr/> <p>jets airpool : 12</p>	<p>V HZ KW A 220/240 50/60 0,78 4,5</p> <p><b>ELETTRO POMPA AIRPOOL</b></p> <p>V HZ KW A 220/230 50/60 0,65 3</p>	<p>C : Allaccio acqua calda rubinetteria parete: 1/2" F : Allaccio acqua fredda rubinetteria parete: 1/2" CB : Allaccio acqua calda bordo vasca: 1/2" FB : Allaccio acqua fredda bordo vasca: 1/2" T : Allaccio miscelatore per erogazione da troppopieno: 1/2" S : Allaccio scarico incassato a pavimento: 1-1/2" E : Allaccio elettrico idromassaggio (pressacavo PG 11): IPX5</p>	<p>C F : Rubinetteria parete ● ● CFT: Rubinetteria parete con erogazione troppopieno ● ● ▲ CB FB: Rubinetteria bordo vasca ■ ■</p>
GB	WATER SYSTEM SPECIFICATION	POWER SYSTEM SPECIFICATION	CONDITION REQUIRED BEFORE THE INSTALLATION	TAPS COMBINATION
<p><i>N.B. THE INSTALLATION MUST BE CARRIED OUT WITH FLOOR AND WALLS ALRESDY TILED</i></p> <p>Net weight: <b>Kg 60</b> total weight with package: <b>Kg 65</b> Volume with package: <b>m<sup>3</sup> = 0,777</b> Water capacity: <b>Lt 260</b></p>	<p>Numero jets: 8</p> <hr/> <p>jets airpool : 12</p>	<p>V HZ KW A 220/240 50/60 0,78 4,5</p> <p><b>ELECTRO PUMP AIRPOOL</b></p> <p>V HZ KW A 220/230 50/60 0,65 3</p>	<p>C : Wall taps outlet for hot water: 1/2" F : Wall taps outlet for cold water: 1/2" CB : Bath edge taps outlet for hot water: 1/2" FB : Bath edge taps outlet for cold water: 1/2" T : Single outlet for mixed water to supply by overflowing: 1/2" S : Drainage outlet installed in the floor: 1-1/2" E : Power outlet for the wirpool (cabling press box PG 11): IPX5</p>	<p>C F : Wall taps ● ● CFT: Wall taps with water supply by overflowing ● ● ▲ CB FB: Bath edge taps ■ ■</p>